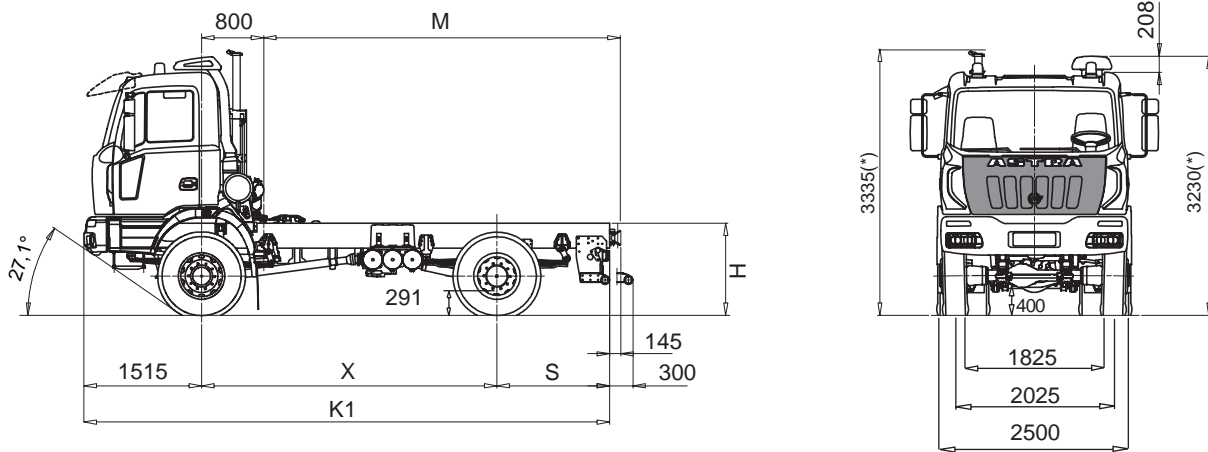

H&DE

chassis 4x4
44.31 / 44.38 / 44.42 / 44.44 / 44.48

(*) unloaded

DIMENSIONS (mm) (Tyres 315/80R22.5 156/150K)

wheelbases	X	K1	M	S	H		TURNING DIAMETER
					UNLOADED	LOADED	
A	3800	6765	4450	1450	1280	1172	14300
B	4200	7565	5250	1850			15650
C	4600	8365	6050	2250			16940
D	5100	8865	6550	2250			18550

WEIGHT (kg)

wheelbases	Distribution net weight (*)			Max. technical weight				
	1 st axle	2 nd axle	net weight	1 st axle		2 nd axle	Gross Vehicle weight	Gross Combination Weight
B	5430	2800	8230	8000	8500 9000 (1)	13000	21000 (2)	55000
C	5470	2800	8270					
D	5500	2820	8320					
E	5570	2790	8360					

(*) Weight including oil, fuel, spare wheel, driver Kg.75

 (1) With tyres 1st axle 385/65R22,5 160J or 365/85R20164G. Other tyres available, subject to the Astra technical office approval.

(2) HD8 44.48 only at max speed 50 km/h. Michelin/Pirelli tyres. Higher speed/load are allowed with load/speed reductions subject to the Astra Technical office approval.



ENGINES

CURSOR 8 F2B and CURSOR 13 F3B turbo intercooler euro 3 diesel injection/cycle with electronic unit injection pumps. 6 in-line cylinders. Single block head, four valves per cylinder, light alloy pistons. Total displacement: 7.790 cm³ for F2B engines and 12.882 cm³ for F3B engines. Bore for stroke: 115x125 mm for F2B and 135 x 150 mm F3B. Water cooling. Viscostatic cooling fan. Dry air filter with safety cartridge. Vertical muffler

	44.31	44.38	44.42	44.44	44.48
Model	IVECO F2B	IVECO F3B	IVECO F3B	IVECO F3B	IVECO F3B
Max. power (EEC)	228 kW (310 HP)	280 kW (380 HP)	309 kW (420 HP)	324 kW (440 HP)	353 kW (480 HP)
Corresponding rpm	2.400	1.900			
Max. torque (EEC)	1.100 Nm (112 kgm)	1.800 Nm (184 kgm)	1.900 Nm (194 kgm)	2.100 Nm (214 kgm)	2.200 Nm (224 kgm)
Corresponding rpm	1.000-1.950	1.000-1.440			
Turbine	VGT variable geometry	WG Waste Gate		VGT variable geometry	



GEARBOX

Manual gear **ZF 16 S 1620 TD** for HD8 44.31 and **ZF 16 S 2220 TO** for HD8 44.38 /HD8 44.42 / HD8 44.44 and **ZF 16 S 2520 TO** for HD8 44.48 - with servoshift, 16 synchronised forward speeds + 2 reverse.

		Speed [kph] at maximum power																		
		Gears																		
		1	2	3	4	5	6	7	8	9	10	11	12	13	14	15	16	RM	RM	
ZF 16 S 1620TD	Gear ratios	16,41	13,80	11,28	9,49	7,76	6,53	5,43	4,57	3,59	3,02	2,47	2,08	1,70	1,43	1,19	1,00	15,36	12,92	
	Rear axle ratio	1:3,793	6,0	7,1	8,7	10,4	12,7	15,1	18,2	21,6	27,5	32,7	39,9	47,4	58,0	69,0	82,9	98,6	6,4	7,6
		1:4,229	5,4	6,4	7,8	9,3	11,4	13,5	16,3	19,4	24,6	29,3	35,8	42,5	52,0	61,9	74,3	88,5	5,8	6,8
		1:5,009	4,6	5,4	6,6	7,9	9,6	11,4	13,8	16,3	20,8	24,7	30,2	35,9	43,9	52,2	62,8	74,7	4,9	5,8
		1:5,558	4,1	4,9	6,0	7,1	8,7	10,3	12,4	14,7	18,8	22,3	27,3	32,4	39,6	47,1	56,6	67,3	4,4	5,2
		1:6,095	3,7	4,4	5,4	6,5	7,9	9,4	11,3	13,4	17,1	20,3	24,9	29,5	36,1	42,9	51,6	61,4	4,0	4,8
1:6,588	3,5	4,1	5,0	6,0	7,3	8,7	10,5	12,4	15,8	18,8	23,0	27,3	33,4	39,7	47,7	56,8	3,7	4,4		
ZF 16 S 2220TO ZF 16 S 2520TO	Gear ratios	13,80	11,54	9,49	7,93	6,53	5,46	4,57	3,82	3,02	2,53	2,08	1,74	1,43	1,20	1,00	0,84	12,92	10,80	
	Rear axle ratio	1:3,793	7,1	8,5	10,4	12,4	15,1	18,1	21,6	25,8	32,7	39,0	47,4	56,7	69,0	82,2	98,6	117,4	7,6	9,1
		1:4,229	6,4	7,7	9,3	11,2	13,5	16,2	19,4	23,2	29,3	35,0	42,5	50,8	61,9	73,7	88,5	105,3	6,8	8,2
		1:5,009	5,4	6,5	7,9	9,4	11,4	13,7	16,3	19,6	24,7	29,5	35,9	42,9	52,2	62,2	74,7	88,9	5,8	6,9
		1:5,558	4,9	5,8	7,1	8,5	10,3	12,3	14,7	17,6	22,3	26,6	32,4	38,7	47,1	56,1	67,3	80,1	5,2	6,2
		1:6,095	4,4	5,3	6,5	7,7	9,4	11,2	13,4	16,1	20,3	24,3	29,5	35,3	42,9	51,2	61,4	73,1	4,8	5,7
1:6,588	4,1	4,9	6,0	7,2	8,7	10,4	12,4	14,9	18,8	22,4	27,3	32,6	39,7	47,3	56,8	67,6	4,4	5,3		



P.T.O.

On request:

Gearbox	ZF16S1620TD	ZF16S2220TO-ZF16S2520TO	Max. torque	Application
P.T.O.	Ratio	Ratio	Nm.	
ZF NH/1b	0,77/0,91:1	0,91/1,09:1	1000	For tipping unit pumps, pumps for cranes, ecc..
ZF NH/1c	0,77/0,91:1	0,91/1,09:1	1000	For tipping unit pumps, unit pumps for concrete, pumps for cranes, ecc..
ZF NH/4c	0,98/1,17:1	1,17/1,40:1	430	For tipping unit pumps, ecc..

Power take off at flywheel (ratio 1,29:1) max available torque 900 Nm for concrete mixers.



CLUTCH

Single dry plate, diameter 17". Pull type engagement with diaphragm spring. Hydro-pneumatic power steering engagement control, with driven disk wear recovery slave cylinder.

TRANSFER

Mechanical with two ratios. It consists of a series of helical spur gears, mounted on three propeller shafts, engaged with each other.

Differential can be locked by pneumatic control.

Transmission ratio: 1:1 - 1:1,6

Front/rear torque distribution ratio: 1:2,2

AXLES

FRONT

Steering cast iron type; with dual reduction, central by pinion-crown gear, side by means of epicycloidal assembly in wheel hubs.

On request:

Lockable differential by pneumatic control from driver's seat.

REAR

engine axle with dual reduction, central with bevel gear pair, final in wheel hubs by means of epicycloidal assembly. Differential lockable with pneumatic control from driver's seat.

On request:

Rear-axle ratio 1:3,793

Rear-axle ratio 1:4,229

Rear-axle ratio 1:5,009

Rear-axle ratio 1:5,558

Rear-axle ratio 1:6,095

Rear-axle ratio 1:6,588

SUSPENSIONS

FRONT

Parabolic springs with bushings, n° 4 leaves 24x90 mm, with shock absorbers and stabilizer bar.

On request:

Reinforced parabolic springs, n° 5 leaves 24x90 mm.

Extra-reinforced conventional springs, n° 10 leaves 15x90 mm.

REAR

Parabolic springs with bushings, n° 4 leaves 24x90 mm, + 1 leaf 50x90 mm, with shock absorbers and stabilizer bar.

CHASSIS

Special steel with high elasticity limit, two flat and parallel side members width 820 mm, C section 320x70x8 mm, cross members riveted to the frame.

Steel front bumpers with headlamp protection grids, front manoeuvring hook, rear underrun bar, steel fuel tank capacity 300 litres.

On request:

Rapid attachment for compressed air for tyres'inflation.

Rear underrun bar in set back position.

Extra long underrun bar for concrete mixer.

Rear manoeuvring hook.

Rear automatic towing hook.

Rubber mudguards on 2nd axle.

Front bumper climbing step.

Side windlass for spare wheel.

PNEUMATIC SYSTEM

Two-cylinder 630 cc compressor, APU (Air Processing Unit) that includes: regulation valve set at 10.3 bar, drier, 4-way safety valve, pressure reduction valve for parking circuit and services. 3 air tanks, capacity 30 litres + 2 with 20 litres. ABS system and EBL (Electronic Brake Limiter)

TYRES

FRONT: 315/80R22,5 156/150 K Single tubeless

REAR: 315/80R22,5 156/150 K Twin tubeless

Spare wheel on the chassis.

Other Possible combinations:

TYRES	ASSEMBLY	
	FRONT	REAR
13 R 22,5 156/150G	S	D
12 00 R 20 156/150G		
385/65 R 22,5 160J*	S	
315/80 R 22,5 156/150K		D
365/85 R 20 164G*	S	S
395/85 R 20 168G*	S	S
525/65 R 20,5 173F		S

S single

D double

Other tyres available, subject to the Astra technical office approval.

* Mandatory with 9t front axle load.

STEERING

ZF 8098 hydraulic power steering on front axle wheels with variable ratio 1:22.2/1:26.2.

Circuit with main hydraulic pump on engine and emergency pump on gearbox. Steering rods with self-lubricating joints. Height and inclination mechanically adjustable steering wheel.

BRAKES

Front and rear "duo-duplex" self-adjusting wedge type brakes with automatic play take-up.

Total net braking surface 5.874 cm².

ABS system.

Service brake: Pedal controlled air brake, acting on all wheels.

Solo vehicles, two independent circuits, one for 1st axle, one for 2nd axle.

Towing vehicles, three independent circuits, one for 1st axle, one for 2nd axle and another for the trailer.

Emergency brake: Incorporated in service brake.

Parking brake: Manual spring-type mechanical with pneumatic control acting on 2nd axle wheels.

IVECO BRAKE TURBO engine brake:

HD8 310 HP braking power 170 kW (231 HP)

HD8 380/420/440/480 HP braking power 255 kW (347 HP)

On request:

Hydraulic intarder (HD8 44.31 excluded).

1st axle immobiliser system.

OFF/ROAD button for excluding ABS for speed < 15 kph.

HD8 380/420 cv - Front and rear "simplex" self-adjusting brake system.
No ABS system.





ELECTRICAL SYSTEM

Voltage: 24 V

Alternator generator 90 A - 28 V (2520 W).

Accumulators: 2 in series, 143 Ah.

Starter motor 24 V 5,5 kW.

Mechanically controlled electrical circuit breaker.

Phonic wheels and sensors on 1st and 2nd axle.

1 electrical joint 7-pole(ISO 7638) for trailer ABS(if applicable).

1 electrical joints 15-pole(ISO 12089-4091) for trailer lighting (if applicable).

Electrical provision for outfitters.

Provision for diagnostics.

Provision for radio/cb (without speakers)

Glow plug for cold start.

On request:

143 Ah tropicalised accumulators;

170 Ah accumulators;

170 Ah tropicalised accumulators;

220 Ah accumulators;

Reverse alarm;

Electric main current cut-off switch.



CAB

White cab with hydraulic tipping. Built in moulding fiberglass with tubular steel armature. Tested on the most demanding off road routes. Cab suspension with guiding arms, 4 helicoidal springs, double action shock absorbers, anti-roll bar and end-of-stroke pads. Internal panels completely washable and fireproof. 4-speed ventilation and heating system with air recirculation system.

Collapsible first step. Electric power windows on driver and passenger doors. Driver seat with pneumatic suspension and seat belt. Mechanical passenger seat with belts. Tinted athermic windows. Steering wheel adjustable in height and angle.

On request:

Car radio RDS, CD;

Car radio RDS, CD, MP3, Blue Tooth technology;

Compressed air quick coupling for cab cleaning;

Roof hatch;

Air conditioning;

Centralized closing of the doors with remote control;

Extra colour cab: metallic / non-metallic;

Heated and electric powered rear view mirrors;

Cab rear window;

External sun visor.



SERVICE DATA(I)

Engine oil sump and filters	28
Gearbox oil ZF16S1620TD:	11
Gearbox oil ZF16S2220TO/ZF16S2520TO:	13
Power steering oil	8,5
Cab tipping oil	1
Clutch circuit oil	0,5
Transfer oil	6,5
Rear axle with final red. oil	16
Cooling system water	33
Diesel	300



INSTRUMENTATION

Dashboard and ergonomic instrument board contain the function buttons and the identification commands.

Indicator lights: engine oil low pressure, alternator charging low, main beam lights, side lights, engine warm-up, rear fog light, hazard lights, tractor turn indicators, trailer turn indicators (if applicable), rotating lights, cab lifted, axles differential locked, differential lock, front brakes air pressure low, rear brakes air pressure low, trailer brakes air pressure low (if applicable), parking brake engaged, splitter (reduction on), slow speeds (1-4/9-12), power take-off on (if applicable) air filters clogged, power steering oil level low, rear view mirrors heated (if applicable), ABS, trailer ABS (if applicable), main steering circuit failure, steering auxiliary circuit failure.

ASTRA Veicoli Industriali

Via Caorsana, 79

29100 Piacenza (Italy)

Tel. ++39-523/5431

Fax ++39-523/59.17.73

www.astraspa.com

DEALER

Characteristics and equipment are subject to changes without prior notice.



Technical data and general specifications - validity to be checked according to each individual country.